

SERIES 3 POST & PANEL:

SERIES 3 - 3/4" TRIANGULAR POST
 W/RADIUS CORNERS
 PART #1250

SERIES 2-3 REVEAL
 PART #1200

SERIES 3 - 3/4" SLIDE BODY
 PART #1260

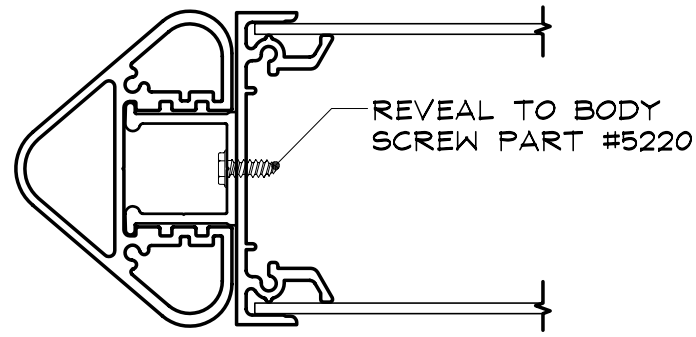

0" REVEAL POSITION

SCALE : 1/2" = 1"

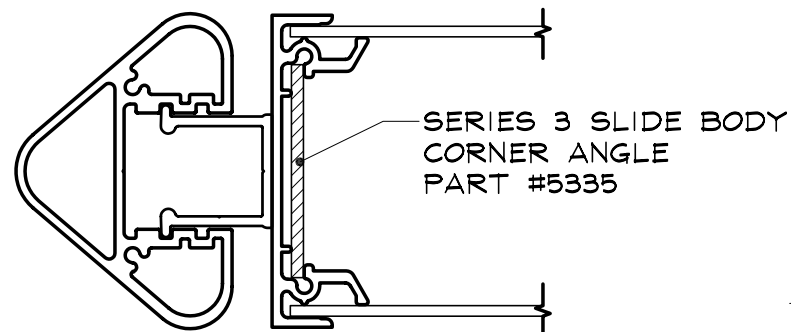

3/8" REVEAL POSITION

SCALE : 1/2" = 1"

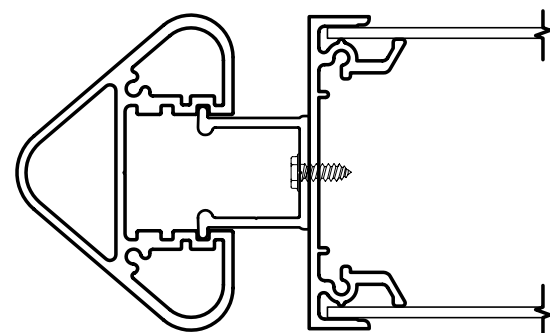

3/4" REVEAL POSITION

SCALE : 1/2" = 1"

FINISH GRADE
 OR
 TOP OF FOOTING

INSERT FILLER
 INTO POST TACK
 WELD IT UP TIGHT UP
 AGAINST SIGN BOTTOM
 LEAVING 6" OF FILLER
 BELOW GRADE.

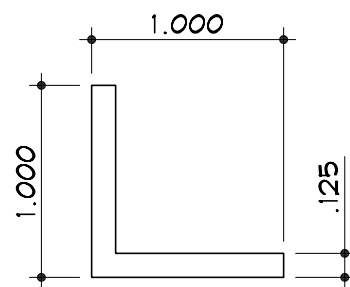
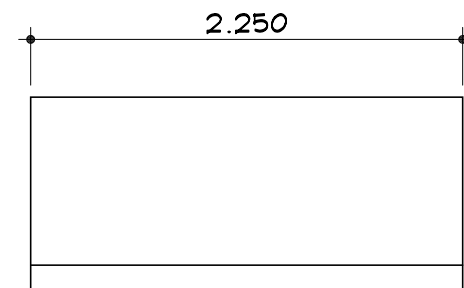

CORNER ANGLE PART #5335

SCALE : 1" = 1"

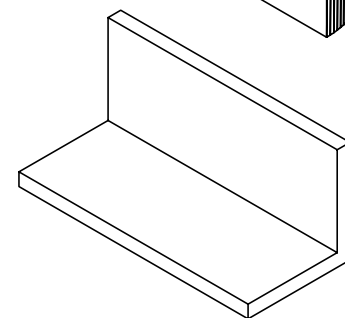
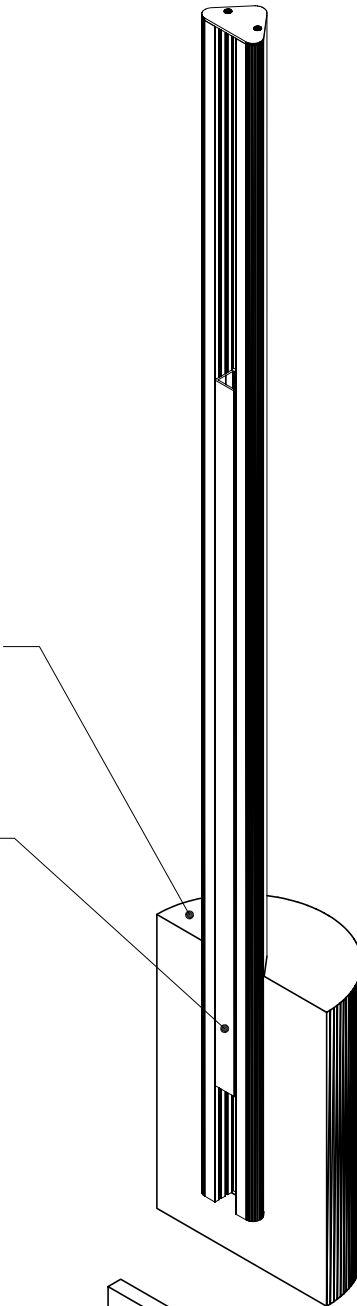

INSTALL REVEAL PIECE
 1/8" BELOW TOP OF SIGN
 TO ALLOW POST CAP
 TO ALIGN FLUSH WITH
 TOP OF SIGN.

SER 3 - 1250-1

